

DUAL SRL CARABINER

Part Number: PN169-SK

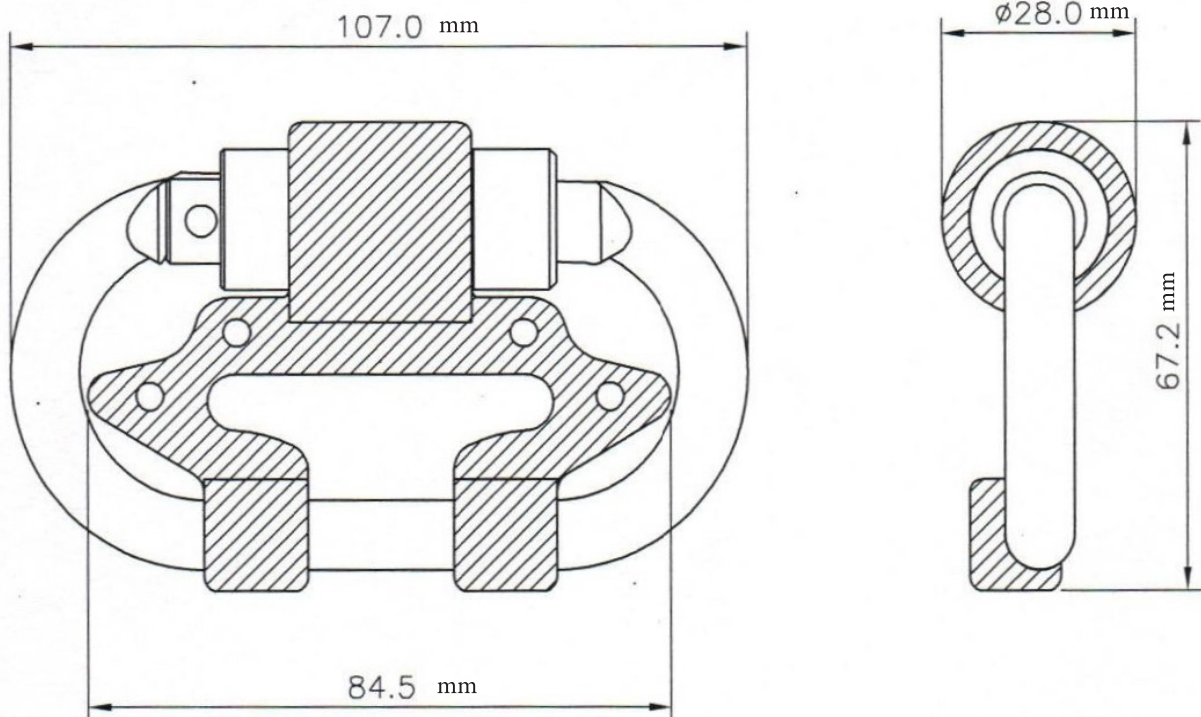

CE 0120



Tested as per EN362:2004 Class B, ANSI Z359.1

SPECIFICATIONS

Design	<ul style="list-style-type: none">▶ Ultimate solution to attach two 6 ft. SRLs directly with user's harness, no additional connector required▶ Reduces the length of swing during the fall thereby preventing impact of SRLs on the back of user's head.
Material	<ul style="list-style-type: none">▶ Carabiner: alloy steel▶ Separator: high-density Polyethylene
Finishing	<ul style="list-style-type: none">▶ Carabiner: zinc plated with yellow/silver passivation
Breaking Strength	<ul style="list-style-type: none">▶ 5,170 lbs. (Minimum)
Weight	<ul style="list-style-type: none">▶ 0.52 lbs. ± 0.02 lbs.
Applicable Standards	<ul style="list-style-type: none">▶ Meets or exceeds ANSI Z359.1

Safe Keeper Fall Protection is committed to providing high-quality fall protection equipment and systems to create a safer work environment and ultimately save lives in the workforce. We use today's cutting-edge manufacturing processes and experts, applying real-world practical knowledge to engineer effective yet affordable solution-focused products.

