

**Safe Climber**

product  
 literature

System Ref: Vertex PN8000-SK

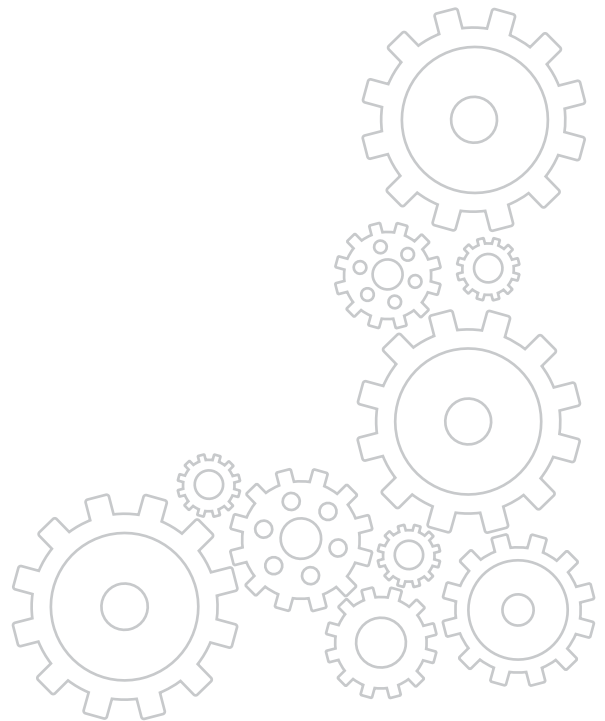

**Manufacturer :**

SAFE CLIMBER, 314 E. CANAL ST. MULBERRY, FL 33860



CHAPTER 1 KNOW YOUR SYSTEM	01
CHAPTER 2 GENERAL DESCRIPTION OF PARTS	02-09
CHAPTER 3 INSTALLATION OF SYSTEM	10-13
CHAPTER 4 PRE USE CHECKS AND PRECAUTIONS	14
CHAPTER 5 PRECAUTIONS WHILE USING THE SYSTEM	15



# CONTENT



# CHAPTER - 1

## KNOW YOUR SYSTEM

### 1 Component Chart

The Chart below shows all the components of the Vertex PN8000-SK Vertical Lifeline Systems with their appropriate ref. no's and quantity required in a system.

Sr. No.	Name of Component	Ref. No of Component	Description
1	Alu Extension	PN8000-SK (02)	Material: Extruded Aluminum Alloy Length: 1.5 m
2	Aluminum Rail Intermediate	PN5000-SK(01)	Material: Extruded Aluminum Alloy Length: 3m
3	Vertical Trolley	PN8000-SK (01)	Material: Stainless Steel (316) Trolley with Brass wheels which provide frictionless movement.
4	Carabiner	PN 111	Quarter Turn Auto-locking Steel Carabiner
5	Ceiling Mounting Bracket	PN5000-SK(06)	Material: Stainless Steel 316 Help to mount the ladder on to the underlying structure.
6	Junction	PN5000-SK(08)	Used to connect two rails together. Material: Stainless Steel 316
7	Aluminum Rail Extremity	PN5000-SK(08)	Material: Extruded Aluminum Alloy Length: 3m
8	Mounting Nut	PN5000-SK(03)	Material: Stainless Steel 316 to connect the rail to the mounting Bracket.

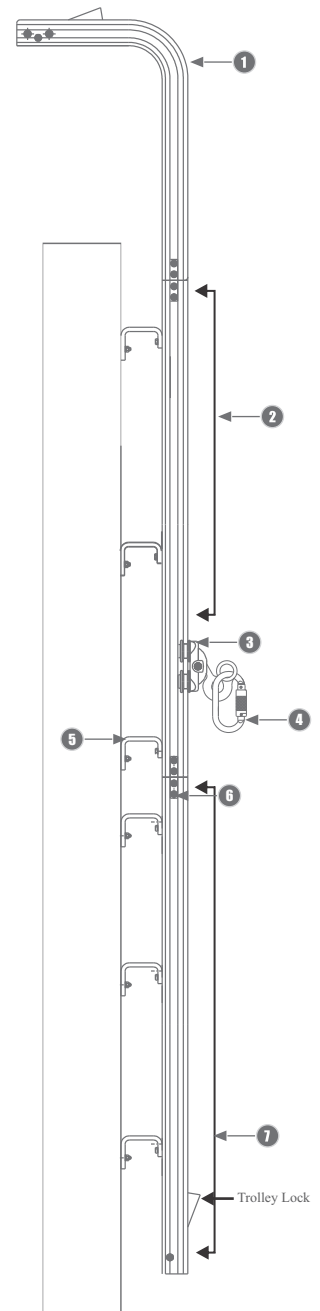



## CHAPTER -2

### GENERAL DESCRIPTION OF PARTS OF VERTEX PN8000-SK

#### 2.1 Alu. Rail Extension: Ref. PN8000-SK (02)

The Alu Rail. Extension arm provides supports to the user at the landing platform. The user can now disengage the trolley while safely standing on the landing platform



PART LIST / BILL OF MATERIALS			
S. No.	Item/Description	Qty.	Ref. DWG. No.
1	Alu Rail Extension	1	PN8000-SK(02.1)
2	Trolley Halt Jib	1	PN5000-SK(02.2)

- Application : The system comes with an extension arm that curves at the ladder end over the working platform. This allows the climbers to be connected with the trolley even at the ladder termination, ensuring complete safety.
- Operating Temperature : -30°C to +50°C (-86° F to + 122° F)
- Material : Aluminum Alloy
- Weight : 2.9Kg.(6.39 lbs)



## 2.2 Alu. Rail Intermediate: Ref. PN5000-SK(01)

The Alu. Rail Intermediate is the Aluminum rail on which the trolley slides smoothly without friction

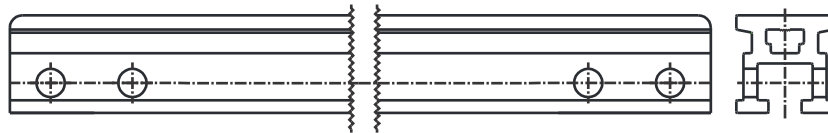

Application	:	The design of the Aluminum rail intermediate provides easy and friction free movement of the trolley. The Aluminum rail intermediate comes in standard length of 3mtrs(118.1"). The Aluminum rail intermediate may be connected by a junction PN5000-SK(08)
Operating Temperature	:	-30°C to +50°C (-86° F to + 122° F)
Material	:	Aluminum Alloy
Weight	:	4.0 Kgs.(8.81 lbs) For a Length of 3 mtrs (118.1")



### 2.3 Vertical Trolley: Ref. PN8000-SK (01)

The Vertical trolley travels up and down on the Alu. Rail along with the user. In the event of a Fall the trolley arrests the fall. In Combination with a harness with a ventral attachment. The trolley assists the user while climbing.

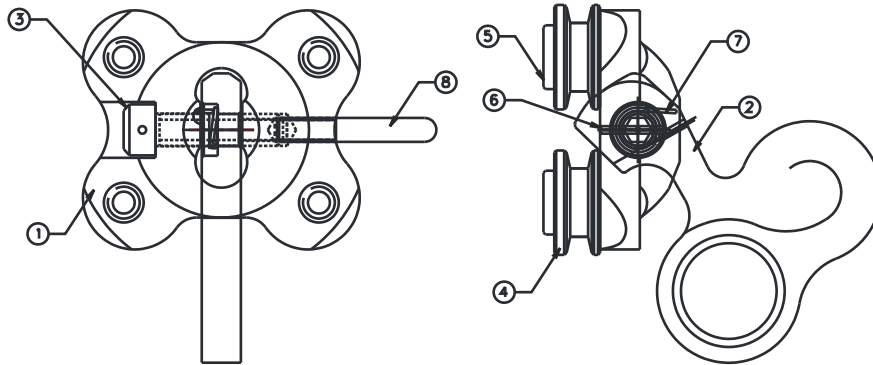

Part List / Bill of Materials			
S. No.	Item / Description	Part No.	Qty.
1	Vertical Trolley	PN8000-SK(1.1)	1
2	Trolley Lock	PN8000-SK(1.2)	1
3	Hexagon Socket Bolt	PN8000-SK(1.3)	1
4	Trolley Roller	PN5000-SK(12.4)	4
5	Trolley Roller Pivot Plug	PN5000-SK(12.5)	4
6	Split Dowel Pin	PN8000-SK(1.6)	1
7	Spring	SPSS046	1
8	Safety Clamp Stopper	PN8000-SK(01.7)	1

- Application : The trolley moves up and down on the line accompanying the connected user and locks over the rail in case of a fall. In combination with a harness with a ventral attachment it assists the user in climbing.
- Operating Temperature : -30°C to +50°C (-86° F to + 122° F)
- Material : SS 316
- Weight : 600 gm. (1.32 lbs)



#### 2.4 Carabiner: Ref. PN 111

The carabiner connects the vertical trolley to the user's harness.

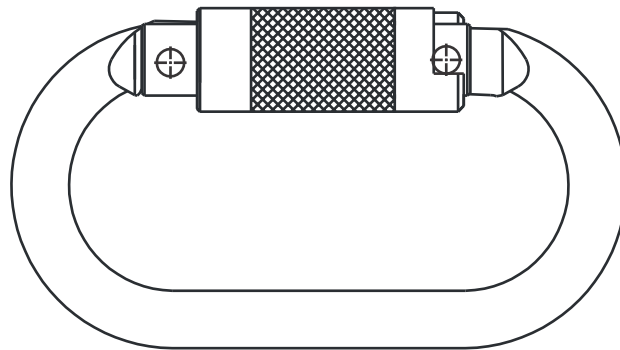

Application	:	Quarter turn locking steel carabiner is used to connect the trolley to the full body harness of the user.
Operating Temperature	:	-30°C to +50°C (-86° F to + 122° F)
Material	:	High Strength Alloy Steel.
Finish	:	Shot Blasted & Zinc Plated
Weight	:	170 gm. (0.37 lbs)



### 2.5 Rung Clamp: Ref. PN8000-SK (03)

The Alu. Rail can be mounted directly on to ladder rungs by the rung clamp. The rung clamps may be mounted at every 1.5 mtrs (59").

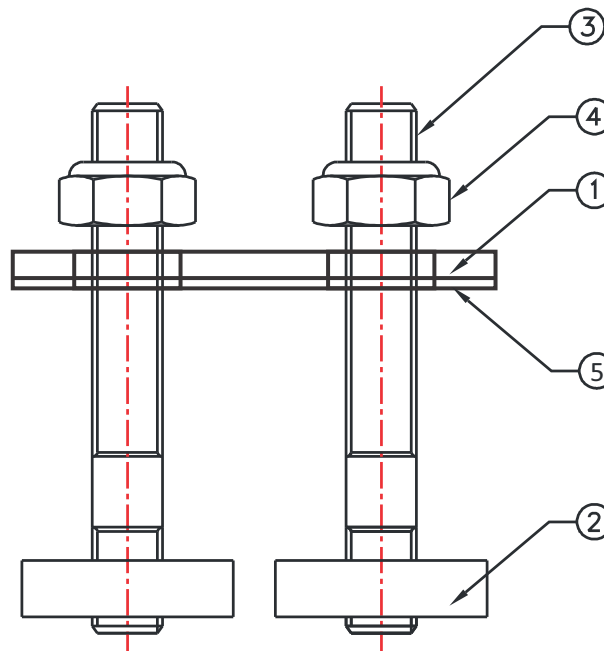

Part List of Rung Clamp: Ref PN8000-SK(03)			
S. No.	Part Description	Part No.	Qty.
1	Fisher Plate	PN8000-SK(03.1)	1
2	Rectangular Nut M10	PN8000-SK(03.2)	2
3	Stud	PN8000-SK(03.4)	2
4	Nylock Nut M10	PN8000-SK(03.5)	2
5	Separator Plate	PN8000-SK(03.6)	1

- Application : The Rung clamp helps to hold the Aluminum rail against the ladder rung.
- Operating Temperature : -30°C to +50°C (-86° F to + 122° F)
- Material : SS 316
- Finish : Electro polished





### 2.6 Junction: Ref. PN5000-SK(08)

The Alu. Rail comes in standard lengths of 3 mtrs(118.1"). When the height is more than 3 mtrs multiple lengths may be joined easily by the junction kit.

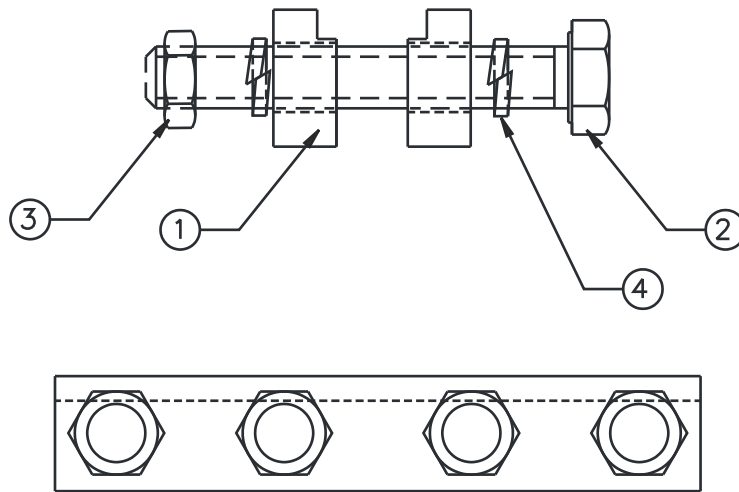

Part List Junction: Ref. PN5000-SK(08)			
S. No.	Part Description	Part No.	Qty.
1	Clamp	PN5000-SK(08.1)	2
2	Bolt	PN5000-SK(08.2)	4
3	Plain nut	PN5000-SK(08.3)	4
4	Spring Washer	PN5000-SK(08.4)	8

- Application : Junction are provided to connect different sections of the Alu. Rail system.
- Operating Temperature : -30°C to +50°C (-86° F to + 122° F)
- Material : Stainless Steel
- Weight : 1.16 Kgs.(2.55 lbs)



### 2.7 Alu. Rail Extremity: Ref. PN5000-SK(02)

The Alu. Rail extremity has a spring loaded termination which ensures that the trolley dose not accidentally move off the rail.

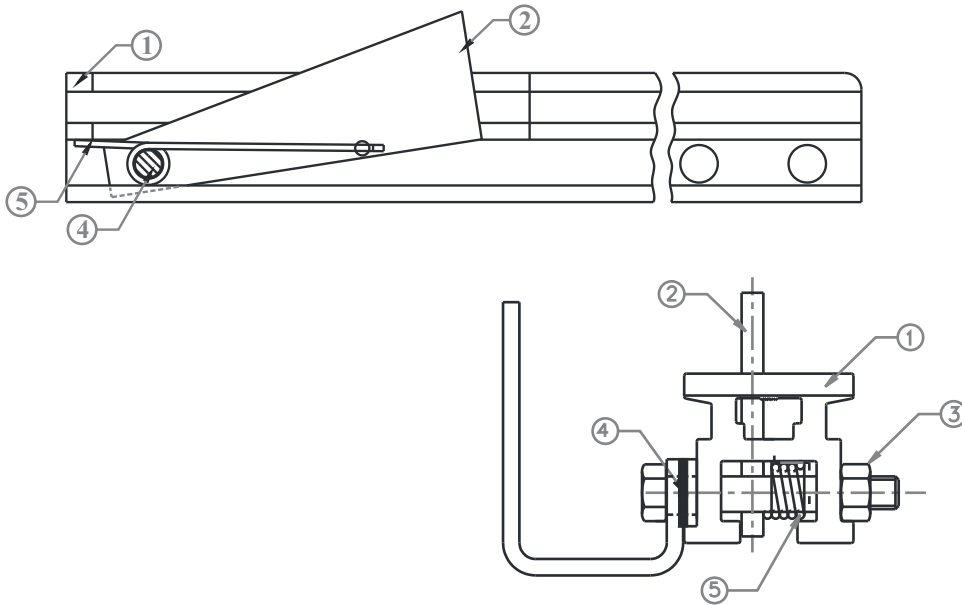

PART LIST / BILL OF MATERIALS			
S. No.	Item/Description	Qty.	Ref. DWG. No.
1	Horizon Alu rail Extremity	1	PN5000-SK(02.1)
2	Trolley Halt Jib	1	PN5000-SK(02.2)
3	Hexagonal Nut	1	PN5000-SK(02.3)
4	Hexagonal Bolt	1	PN5000-SK(02.4)
5	Left Hand Torsion Spring	1	SPSS035

- Application : The aluminum rail extremity comes in a standard length of 3mtrs. and can be connected to the Alu. Rail Intermediate PN5000-SK(01) by a junction PN 5000(08). The Alu. Rail extremity has a trolley halt jib at one end to prevent the trolley to move off the Alu. Rail accidentally.
- Operating Temperature : -30°C to +50°C (-86° F to + 122° F)
- Material : Aluminum Alloy
- Weight : 4.1 kgs(9.03 lbs)



**2.8 Inspection Plate : Ref. PN8000-SK (09) (Marking)**

The Inspection name plate is installed on the first rung of the ladder for identification, traceability and maintenance of inspection records. Two stainless steel cable ties are used to fasten the system name plate to the structure. At time of installation the relevant details are punched on the plate by a number punch. The re-validation dates are punched each year on the plates after inspection and re-validation.

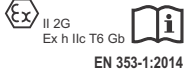
		
○	ADDRESS :	Safe Climber, 314 E. Canal St. Mulberry, FL 33860
	PRODUCT :	Vertical Anchorage Line System on Rigid Aluminum Rail
	CODE :	PN8000-SK
1 of 2		
BATCH NO. :		YEAR OF MFG.:
LENGTH :		MTRS.
INSTALLATION DATE : / /		
INSPECTION REPORT :		Date : / /
REVALIDATION DUE ON :		
2 of 2		



## CHAPTER -3

### INSTALLATION OF SYSTEM VERTEX PN8000-SK

#### 3.1 Pre-Installation Inspection of the Receiving Structure

The receiving structure on which the system is to be installed should be strong enough to hold an impact load of more than 12 kN(2645 lbs). Safe Climber shall not be held responsible in any failure arising out of the failure of the structure.

It is hence essential to calculate the strength of the receiving structure before the installation.

If in doubt a competent person or a qualified structural engineer may study the drawings or visit the site and verify the adequacy of strength of the receiving structure.

The System PN8000-SK is installed in the following way:



### 3.2 Installation of the System

The System PN8000-SK is installed in the following way:

#### Step 1: Mounting Nut Ref. PN5000-SK(03)

Insert Mounting nuts into the Alu. Rail extremity. The first mounting nut must be 300mm from the bottom edge of the Alu Rail extremity. The second mounting nut needs to be 1500mm from the first mounting nut.

Maintain a distance of 1.5 mtrs(59") between all mounting nuts in the complete system.

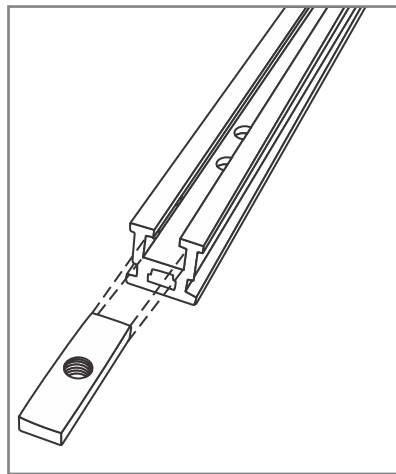

#### Step 2: Alu Rail Extremity: Ref. PN5000-SK(02)

- ♦ Install the Alu rail extremity on the ladder using Rung clamp PN5000-SK(03)
- ♦ The Position of Alu Rail Extremity should be at least 15cms above the ground so that the Trolley can be inserted easily on the rail.
- ♦ The position of the first rung clamp should be 30 cms (11.81") from the bottom edge of the Alu rail Extremity. Thereafter maintain a spacing of 1.5 mtrs(59") between two rung clamps.

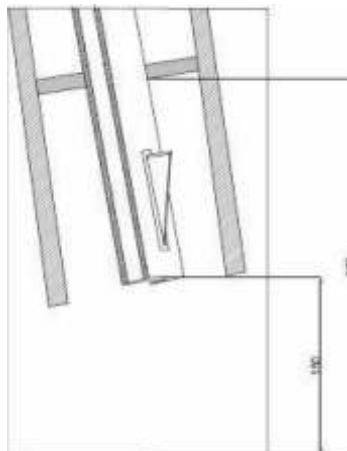



### Step 3: Rung Clamp PN8000-SK(03)

- ◆ Insert the T-bolts into the Aluminum rail and slide it to the appropriate distance where the rung clamp is to be fitted.
- ◆ Hold the T-bolts on either side of the rung.
- ◆ Behind the rung insert the Fischer plate into the T-bolts.
- ◆ Tighten the nuts so that the Fischer plate firmly rests against the rung.
- ◆ The Alu rail is now fixed to the rung. Repeat this process after every 1.5mtrs.
- ◆ Ensure that the first rung clamp is at least 30 cms (11.81") or less from the bottom edge.

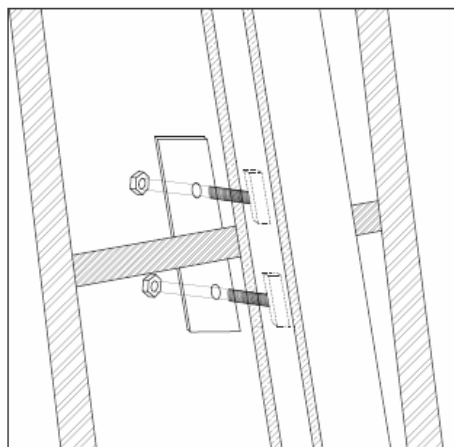

### Step 4: Junction: Ref. PN5000-(08)

Join two lengths of Alu. Rail intermediate.

Match the sections of both the Alu. Rail, Slide the fixture PN5000-SK(08) over the joint so that the joint is in the center of the fixture. This will ensure the perfect alignment of two rails.

Place the junction plate on either side of the Alu. Rail with the holes of junction plate matching with those of Alu. Rail intermediate. Fix both the plates by 4 sets of fasteners.

Ensure that the gap between the two rails is not greater than 1.5 mm.

Remove the fixture from the rail and use it for the next joint.

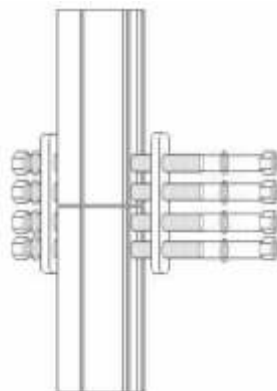



### Step 5: Alu Extension: Ref. PN8000-SK (02)

Repeat the step-4 to join the Alu Extension arm to the Alu rail Intermediate PN5000(01)



### Step 6: Vertical Trolley: Ref. PN8000-SK(01)

- ♦ Insert the trolley in the Alu. Rail extremity. Press the termination of the extremity and pass the trolley over the termination. Ensure that the arrow on the trolley is in upward direction.
- ♦ After the trolley slides on the Alu. Rail the termination cones back to its original position ensuring that the trolley does not slide off the Alu. Rail.
- ♦ The trolley is equipped with a safety locking pin which is obstructed by the L clamp fitted on the Alu. Rail extremity in case the trolley is inserted in the wrong direction.

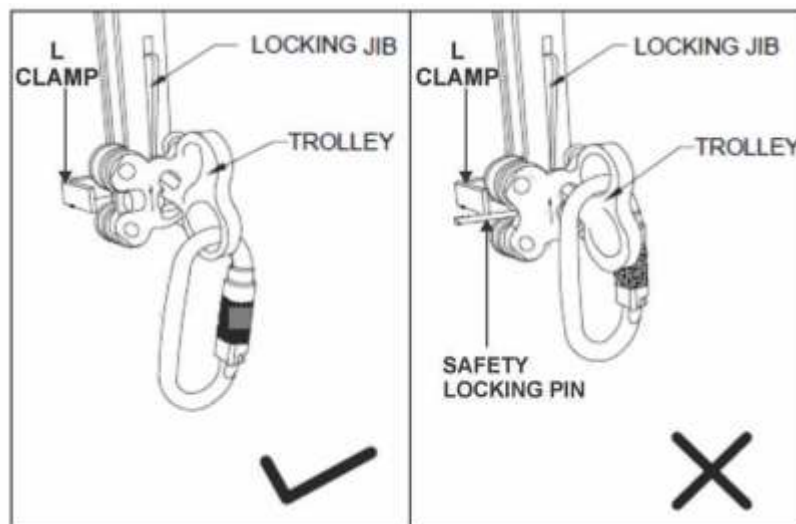



## CHAPTER -4

### PRE-USE CHECKS AND PRECAUTIONS

#### 4.1 Pre Use-Checks

It is mandatory for the Site Inspector/ Supervisor and the actual users of the system to perform a thorough check of the same before carrying out any work. The following points are considered for the Pre-Use check-

##### 4.1.1 Checking the System

- ◆ Keep the system clean of any dust/dirt. Check for any mechanical defects.
- ◆ Check for wear and tear in all components is unusual bending or deformation.
- ◆ Check for any modifications done by the user.
- ◆ Check for any missing component.
- ◆ Check for any damages that may have been caused due to welding while maintenance of other equipment.
- ◆ Check the Identification Plate. The system needs to be put out of service if the label is not legible or missing.

##### 4.1.2 Checking the Trolley & Connector

- ◆ Check the movement of the Trolley and its grip before each climb.





## CHAPTER -5

### PRECAUTIONS WHILE USING THE SYSTEM PN8000-SK

#### 5.1 The following points of precautions needs to be considered for safe use of the system PN8000-SK

- ♦ The life line is for the purpose of fall protection while climbing up or down the ladder. A back up fall arrest system is required when transitioning on and off the life line system while working at height.
- ♦ The user should not suspend himself on the Trolley.
- ♦ Never disengage the Trolley while climbing up or down.
- ♦ Prevent the Trolley from falling from a height.
- ♦ Do not put grease to lubricate the system.
- ♦ If any fall is reported put the system out of use. Contact the manufacturer for repairs and re-validation.
- ♦ Full body harness which comply EN 361 with front attachment anchorage points should be used in conjunction with Vertex PN8000-SK System.
- ♦ Do not alter or misuse this equipment. Usage of certain component/sub system may interfere with the proper functioning of this equipment and the system may not deliver the working as per its intended use.
- ♦ The lifelines must be kept free from dust, grease etc., by periodic cleaning. The system can be cleaned by a soft dry cloth.

**5.1.1** Hazards existing in the immediate environment may require additional precautions to limit the possibility of injury to the user or damage to the equipment. Hazards may include but are not limited to, extreme temperatures, caustic chemicals, corrosive environments, high voltage power lines, explosive or toxic gases, moving machinery, sharp edges, high velocity winds etc. Do not expose the equipment to any hazard which it is not designed to withstand. Consult the manufacturer incase doubt.

**5.1.2** Rescue Plan: It is mandatory to ensure that the user should have a rescue plan and means to execute it while using this equipment. The rescue plan needs to be project specific. The employees must be trained in self-rescue or alternative means should be provided for prompt rescue in the event of a fall..



## WARNING & LIMITATIONS

- ♦ Full Body harness should be properly adjusted to snug fit and should not be used if loose. If the harness becomes loose during the ascent and descent it should be correctly adjusted again from a secured position.
- ♦ Length of the connecting element shall not extend or shortened e.g. by adding or subtracting a connector.
- ♦ Mass of the user including clothing and equipment shall not be less than 35kg and shall not exceed 100kg.
- ♦ PN111 shall be used in conjunction with the vertical anchorage line PN8000.
- ♦ Engaging a guided type fall arrester's release function during ascent or descent could hinder the safe operation of breaking mechanism and should be done only from a safe position where there is no risk of fall.
- ♦ Guided type fall arrester shall not be used for work positioning and if required a separate system shall be used.
- ♦ Connection and disconnection from rigid anchorage line shall be done from a safe place or by using a secondary personal fall protection system.
- ♦ Orientation of the anchorage line shall not be inclined more than 1° from vertical position.
- ♦ Rigid anchor line should not be installed in highly corrosive atmosphere because of risk of non visible stress corrosion cracking, unless specified controlled measures are in place.
- ♦ The user is warned to be care full about the medical conditions that could his safety in normal and emergency use.
- ♦ The fall arrester should be used by a person trained and competent in its safe use.
- ♦ The fall arrester shall not be used outside its limitations or for any purpose other than fall arrest.
- ♦ It should be a personal property of the user.
- ♦ To optimize protection, in some instances it may be necessary to use the fall arrester with suitable boots/gloves/helmet/ear defenders. In this case, before carrying out the risk-related activity, consult your supplier to ensure that all your protective products are compatible and suitable for your application. Compatibility within a fall arrest system can be checked on the check card below.
- ♦ Make a visual inspection of the system to ensure that it is in a serviceable condition & operates correctly. Also ensure that the recommendations for use with other components within a system as advised on the check card are complied with. Ensure that the harness used conforms to EN361 and the carabiner is connected to the attachment element of the harness. Also ensure that the harness has an attachment point located appropriately in relation to the fall arrester. We recommend the user to use Full Body Harness with front attachment elements only. Use the fall arrester only with the Anchorage Line supplied by the manufacturer.  
While attaching the anchorage line to the anchor point, only use carabiners according to DIN EN 362.
- ♦ In case of any doubt arising about the safety of the fall arrester, it should be replaced immediately on consultation with an expert.
- ♦ Withdraw from use any fall arrester that has been used to arrest a fall & return it to the manufacturer or competent repair center for servicing & retest. Do not use again until confirmed in writing by a competent person that it is acceptable to do so
- ♦ While using the fall arrester, it is essential for safety to verify the free space required beneath the user at the work place before each occasion of use. It should be min. 2.5ms below the feet of the user.
- ♦ If the product is re-sold outside the original country of destination, the reseller shall provide instructions for use, for maintenance & periodic examination and for repair in the language of country of purchase.



- ♦ Alu rail system shall be used only with guided type fall arrester vertical trolley PN8000-SK(01).
- ♦ It is essential for the safety of the user that if a product is re-sold outside the original country of destination the reseller shall provide instructions for use for maintenance, for periodic examination and for repair in the language of the country in which the product is to be sold.

### INSTRUCTIONS FOR MAINTENANCE

- ♦ Proper maintenance of the equipment is essential for its successful performance.
- ♦ Regular cleaning is essential. In case of miner soiling, wipe with cotton cloth or soft brush. Do not use abrasive material. For intensive cleaning, it can be washed with water using neutral detergents. Do not use acid or basic detergents. Strictly follows the cleaning procedure as mentioned.
- ♦ If the fall arrest becomes wet, it should be allowed to dry naturally & kept away from direct heat.
- ♦ Store in a cool dry place. Avoid humid & acidic environment for storage.

### INSTRUCTIONS FOR PERIODIC EXAMINATIONS

- ♦ It is emphasized that periodic examination of the fall arrester is important as the safety of the user depends upon continued efficiency and durability of the equipment.
- ♦ It is recommended that the fall arrester is periodically examined at least once every year.
- ♦ The periodic examination should be conducted by a competent person and strictly in accordance with our laid procedures.
- ♦ It is important to check the legibility of the markings in every examination.

### Check Card

It is recommended that the fall arrestor should be inspected and examined by an expert for any damages or failures if the need arises, but at least once a year. The observations should be recorded in the table below. In case such damages are observed, the fall arrester should be replaced immediately.

The fall arrestor shall only be used within a fall arrest system according to EN 363:1993 in combination with a full body harness according to EN 361:2002 and connectors according to EN 362:2004.

The instructions for use for the individual components are to be observed.

### SERVICE AND INSPECTION RECORD

Date	Damage observed	Repair measures	Comments

### IDENTIFICATION

1. Type	5. Date of Purchase
2. Identification mark	6. Date of first use
3. Batch No.	7. Name of user
4. Year of manufacture	8. Comments